Research Article: Theory/New Concepts | Integrative Systems

Communication between Brain Areas Based on Nested Oscillations

Brain communication based on nested oscillations

Mathilde Bonnefond^{1,2}, Sabine Kastner³ and Ole Jensen⁴

¹*Donders Institute, Centre for Cognitive Neuroimaging, Radboud University, Nijmegen, Netherlands Kapittelweg 29*

²*Institut National De La Santé Et De La Recherche Médicale U1028, Centre National De La Recherche Scientifique UMR S5292, Centre De Recherche En Neurosciences De Lyon, Bron, France*

³*Princeton Neuroscience Institute & Department of Psychology, Princeton University, Princeton, NJ 08544*

⁴*School of Psychology, University of Birmingham, Birmingham, B15 2TT, UK*

DOI: 10.1523/ENEURO.0153-16.2017

Received: 8 June 2016

Revised: 25 January 2017

Accepted: 14 February 2017

Published: 10 March 2017

Author contributions: MB, SK and OJ wrote the paper.

Funding: James S. Mc Donnell foundation
220020448

Conflict of Interest: Authors report no conflict of interest.

Ole Jensen and Sabine Kastner acknowledge support from the James S. McDonnell Foundation Understanding Human Cognition Collaborative Award 220020448.

Correspondence should be addressed to Mathilde Bonnefond, telephone: +31 (0) 24 36 10979; fax: +31 (0)24 36 10989; Email: mathilde.bonnefond@inserm.fr

Cite as: eNeuro 2017; 10.1523/ENEURO.0153-16.2017

Alerts: Sign up at eneuro.org/alerts to receive customized email alerts when the fully formatted version of this article is published.

Accepted manuscripts are peer-reviewed but have not been through the copyediting, formatting, or proofreading process.

This is an open-access article distributed under the terms of the Creative Commons Attribution 4.0 International (<http://creativecommons.org/licenses/by/4.0>), which permits unrestricted use, distribution and reproduction in any medium provided that the original work is properly attributed.

Copyright © 2017 the authors

1
2
3
4
5
6
7
8
9
10
11
12
13
14
15
16
17
18
19
20
21
22
23
24
25
26
27

Communication between brain areas based on nested oscillations

Abbreviated title: Brain communication based on nested oscillations

Mathilde Bonnefond^{1,2}, Sabine Kastner³ and Ole Jensen⁴

1. Radboud University, Nijmegen.

Donders Institute, Centre for Cognitive Neuroimaging

Kapittelweg 29

6525 EN Nijmegen, Netherlands

2. Institut National de la Santé et de la Recherche Médicale U1028

Centre National de la Recherche Scientifique UMR S5292

Centre de Recherche en Neurosciences de Lyon

Bron, France

3. Princeton Neuroscience Institute & Department of Psychology

Princeton University

Princeton, NJ 08544

4. University of Birmingham

School of Psychology

Birmingham B15 2TT, UK

mathilde.bonnefond@inserm.fr

telephone: +31 (0) 24 36 10979

fax: +31 (0)24 36 10989

28 **Author Contributions:**

29 MB, SK and OJ wrote the paper

30 **Number of Figure:** 4

31 **Number of words for Abstract:** 132

32 **Number of words for Significance Statement:** 56

33 **Conflict of Interest:** No

34 **Funding sources:**

35 Ole Jensen and Sabine Kastner acknowledge support from the James S. McDonnell Foundation

36 Understanding Human Cognition Collaborative Award 220020448.

37

38 **Abstract**

39 Unraveling how brain regions communicate is crucial for understanding how the brain
40 processes external and internal information. Neuronal oscillations within and across brain
41 regions have been proposed to play a crucial role in this process. Two main hypotheses have
42 been suggested for routing of information based on oscillations, namely the ‘communication
43 through coherence’ and the ‘gating by inhibition’ frameworks. Here, we propose a framework
44 unifying these two hypotheses that is based on recent empirical findings. We discuss a theory in
45 which communication between two regions is established by phase-synchronization of
46 oscillations at lower frequencies (<25Hz), which serve as temporal reference frame for
47 information carried by high frequency activity (>40Hz). Our framework, consistent with
48 numerous recent empirical findings, posits that cross-frequency interactions are essential for
49 understanding how large-scale cognitive and perceptual networks operate.

50 **Significance statement**

51 To understand how the brain operates as a network it is essential to identify the
52 mechanisms supporting communication between brain regions. Based on recent empirical
53 findings, we propose a novel mechanism for selective routing based on cross-frequency coupling
54 between slow oscillations in the alpha and gamma band.

55 **Main text**

56 Humans operate in complex environments requiring the encoding and processing of the
57 constant flow of sensory information. While the information must be prioritized, the mechanisms
58 underlying the selective routing of sensory information remain to be understood. Neuronal
59 oscillations, in which excitability is modulated by the phase of the rhythm, have been proposed
60 to play important mechanistic roles for routing information, since they can change the dynamic
61 interactions between brain regions on a fast time scale (Varela, et al. 2001). Two hypotheses
62 have been proposed for routing of information based on oscillations: the ‘communication
63 through coherence’ (CTC; Bastos, et al. 2015, Fries 2005, 2009) and the ‘gating by inhibition’
64 (GBI; Jensen and Mazaheri 2010) frameworks (see also Akam and Kullmann 2014). The CTC
65 framework, at least in its initial form, mainly focused on gamma activity (>30Hz) while the GBI

66 is mainly based on alpha oscillations (8-13Hz). These two frameworks are not mutually
67 exclusive and the aim of this paper is to unify them.

68 **The CTC and GBI frameworks**

69 Consider two pools of neurons A and B that are connected to a third pool C. As an
70 example, this could be two subpopulations of neurons representing different spatial locations
71 within V1 and project to a common subpopulation of V4 neurons that represent both spatial
72 locations. When spatial attention is directed to the receptive fields (RFs) of neurons in pool A,
73 the routing mechanism should favor the communication between A and C while preventing the
74 communication between B and C (figure 1a). How is the functional connectivity between A and
75 C, but not B and C, established?

76 According to the CTC hypothesis, inter-regional communication is established when the
77 oscillatory activity between these neuronal pools is coherent, i.e. they oscillate at the same
78 frequency with a stable phase difference (Fries 2005, 2009). This would allow the excitable
79 phase of neurons in C to coincide with synaptic input from neurons in A. To block the
80 communication (the B to C pathway), the synaptic input from neurons in B arrives at the non-
81 excited phase of the neuron in C (figure 1b). Thus if B and C are not oscillating in phase-
82 synchrony the communication is reduced. Brain regions have indeed been shown to phase-
83 synchronize in the gamma band when attention is allocated (e.g. Bosman, et al. 2012,
84 Womelsdorf, et al. 2006, Womelsdorf, et al. 2007). How is the phase-synchrony between regions
85 A and C established? Fries and colleagues (Bastos, et al. 2015, Fries 2009) proposed that it is
86 established by oscillations in neurons of pool A entraining neurons in C at the gamma frequency.
87 This mechanism also implies that the phase-synchronization among the neurons in A is stronger
88 and potentially oscillates at a faster gamma frequency than in B (Fries 2015). As a consequence,
89 the neurons in C are entrained by A rather than B, thus dynamically strengthening the functional
90 connectivity. This effect results in a mechanism that increases the impact of A on C while
91 reducing the impact of B on C (Fries 2009, 2015). It is not completely clear how B and C
92 achieve asynchrony (Akam and Kullmann 2014). As demonstrated in Bosman et al. (Bosman, et
93 al. 2012), coherence between B and C is reduced as compared to coherence between A and C.
94 The reduced coherence could be achieved by B and C fluctuating independently in the same
95 frequency band, or by B and C oscillating at different frequencies (as shown in Bosman, et al.

96 2012). Yet, a possibility is that they oscillate at the same frequency but with a fixed phase
97 difference (e.g. anti-phase); however, this possibility seems at odds with the reduced coherence
98 in the unattended pathway (Bosman, et al. 2012).

99 According to the GBI hypothesis (figure 1c), the information flow between regions is
100 established by actively inhibiting the pathway not required for the task. It has been proposed that
101 alpha activity reflects regional-specific inhibition (Foxe and Snyder 2011, Jensen and Mazaheri
102 2010, Jensen, et al. 2012, Klimesch, et al. 2007). Alpha activity is associated with pulses of
103 inhibition, i.e. the larger the alpha activity, the stronger the bouts of inhibition. This is consistent
104 with findings from many experiments showing that alpha activity is high over task-irrelevant
105 areas (Bonnefond and Jensen 2012, Capilla, et al. 2014, Haegens, et al. 2010, Snyder and Foxe
106 2010 but see Mo, et al. 2011) or task-irrelevant groups of neurons within a brain area (van
107 Kerkoerle, et al. 2014). Furthermore, this increase has been shown to predict behavioral
108 performance (Bonnefond and Jensen 2012, Bonnefond and Jensen 2013, Foxe, et al. 1998,
109 Haegens, et al. 2011, Haegens, et al. 2012, Handel, et al. 2011, Meeuwissen, et al. 2010, Myers,
110 et al. 2014, Payne, et al. 2013, Thut, et al. 2006). Considering Figure 1a, gating would thus be
111 reflected by alpha power increases in B and a decrease of alpha power in A and C. Furthermore,
112 the alpha power decrease in A and C would allow for increased gamma power in these regions
113 that could be involved in transmitting information. It is important to note that, in the latest
114 version of the CTC framework (Fries 2015), Fries also highlighted the potential role of alpha
115 oscillations, in opposition to gamma oscillations, in preventing effective communication of local
116 neuronal representations but also in holding these representations “on-stock” so they can be
117 flexibly used when needed.

118 Even though both of these frameworks have strong explanatory value, they account for
119 different findings in the literature. In particular, CTC in its current formulation does not address
120 the issue of diverging routes where e.g. one region is connected to two downstream regions. In
121 this case the entrainment by gamma oscillations does not provide a routing mechanism (but see
122 Bastos, et al. 2015, Fries 2015). Several other challenges have been put forward to the CTC
123 framework. One criticism is based on the finding that the gamma frequency is modulated by
124 stimulus features such as contrast (Hadjipapas, et al. 2015, Ray and Maunsell 2010). This implies
125 that different contrast levels that are part of a larger scene (e.g. a single object) are
126 communicated at different frequencies, which might pose a problem for integrating this

127 information in the converging visual hierarchy (Ray and Maunsell 2010). However, Fries (2015)
128 mentioned that the stimulus salience and level of attention to the subparts of a single object are
129 often similar and thus result in similar gamma frequencies facilitating the integration in higher
130 levels of hierarchy. However, a second criticism is based on an optogenetic study that manipulated
131 spike timing in the gamma and beta bands. Manipulating the temporal coordination of spiking
132 activity did not influence behavior or transmission of spikes (Histed and Maunsell 2014). Third,
133 there is a debate as to whether the high frequency activity generated by natural stimuli is
134 dominated by band-limited oscillations in the gamma frequency range or non-oscillatory changes
135 over a broad range of frequencies (Hermes, et al. 2014; see section "Existing evidence and
136 predictions for communication by nested oscillations"). Finally, it has been argued based on
137 results from a modeling study, that while entrainment might occur, communication is established
138 already prior to coherence (Rolls, et al. 2012).

139 Also the GTI framework is associated with several limitations. First, the phase
140 modulation of neuronal firing by the alpha band activity is not made explicit (Jensen, et al. 2012,
141 Jensen, et al. 2014). Second, GTI does not elaborate on the role of gamma band activity for inter-
142 areal communication nor does it consider interregional phase-synchrony in the alpha-band as
143 also being involved in inter-regional communication. Third, the strong emphasis on the alpha
144 band activity seems at odds with many non-human primate studies on attention in which
145 modulations by alpha oscillations have only been recently reported, mainly via the use of laminar
146 recordings (Haegens, et al. 2011, Haegens, et al. 2015, Maier, et al. 2011, Spaak, et al. 2012).

147 At different levels of the cortical hierarchy feedforward and feedback information needs
148 be integrated (see e.g. Larkum 2013 for one proposal). The GTI and CTC proposals are not fully
149 explicit on the integration of feedforward and feedback at the microcircuit level (but see Lee, et
150 al. 2013 cited in Bastos, et al. 2015 and Fries 2015). Therefore it is crucial that these frameworks
151 are unified and extended (e.g. by incorporating the phase coding scheme), so that empirical
152 studies can be specifically designed to test for the predictions derived from such a unified
153 framework.

154

155 **A unified framework based on nested oscillations**

156 We here propose a unified framework which is based on the coupling of slow and fast
157 oscillations (see also Florin and Baillet 2015, Hyafil, et al. 2015, Lakatos, et al. 2005, Schroeder

158 and Lakatos 2009). In this framework (figure 2), we suggest that the information flow is
159 established by neuronal synchronization at lower-frequencies in the theta (4 – 7Hz), alpha (8 –
160 13 Hz) and beta (14 – 25Hz) bands rather than in the gamma band. We will first develop the
161 framework around the alpha band in the visual system (see section “Communication based on
162 nested oscillations could be a general mechanism throughout the brain” for a discussion about
163 the role of beta oscillations in the visual system). This is motivated by the fact that there are a
164 numerous empirical reports on alpha oscillations in the visual system in the context of
165 experiments in which routing is manipulated using attention task. We will then discuss how the
166 framework could generalize to other regions.

167 We consider here that alpha oscillations are associated with pulses of inhibition every
168 ~100 ms and as such can suppress neuronal activity locally as well as support inter-areal
169 communication, through phase-synchronization and release of inhibition (see also section on
170 Control of alpha oscillations in relation to cortical layers). It is important to note that these
171 mechanisms do not exclude complementary roles of alpha oscillations in other processes such as
172 transmitting prior-evidence to sensory areas (Sherman, et al. 2016) or sampling (Busch and
173 VanRullen 2010, Song, et al. 2014, VanRullen 2016; see also section "The role of saccades and
174 slower rhythms").

175 We propose that, when neurons in pool A and C communicate, they oscillate coherently
176 in the alpha band in conjunction with a decrease in alpha power. The decrease in alpha power
177 creates longer windows of excitability in each cycle, i.e. longer duty-cycles (Jensen and
178 Mazaheri 2010), allowing for more information to be transferred between the synchronized
179 regions. The blocking of communication between pool B and C is assured by two
180 complementary mechanisms: asynchrony between B and C preventing communication and
181 stronger alpha power in B resulting in shorter duty-cycles. Asynchrony could mean that the
182 regions are oscillating in anti-synchrony which could imply that they are still coherent. Another
183 possibility is that they are not synchronized, but fluctuating at different phases albeit the
184 frequencies are within the same range. Another possibility would be that pools B and C fluctuate
185 at different frequencies. In the latter case, the prevention of the transfer of information would be
186 mainly implemented via an increase of alpha inhibition.

187 Gamma oscillations are expected to be nested within alpha oscillations, i.e. they should occur
188 only during the excitability phase of alpha oscillations. In pool A, the low magnitude of alpha

189 oscillations allows for longer duty cycles, i.e. longer time-windows for the gamma activity
190 during the excitability phase of the alpha cycle. As the excitable phase of the alpha oscillations
191 will be aligned between the two relevant pools of neurons, gamma activity in A will be able to
192 impact the neurons in C. This fast neuronal synchronization will have a strong impact on C due
193 to synaptic summation within the time window of a gamma cycle (Salinas and Sejnowski 2001).

194

195 As a consequence, gamma oscillations in A and C will be correlated and possibly coherent. In
196 pool B, the high magnitude of alpha oscillations will reduce the duty cycle, i.e. the gamma
197 oscillations duration. In addition, the asynchrony of alpha oscillations in B and C will prevent
198 gamma activity in B to drive cells in C. In short, a coupling between the phase of the alpha
199 oscillations and gamma power could reflect the temporal coordination of information between
200 regions.

201 The significance of alpha synchronization, specifically in a sensori-fronto-parietal
202 network, in sensory processing was also emphasized by Palva and Palva (2007, 2011) and more
203 recently in Siebenhühner et al. (2016). They proposed that cross-frequency phase coupling
204 between alpha, beta and gamma oscillations would allow the selection and maintenance of object
205 representations during perception and working memory. They more specifically proposed that
206 cross-frequency phase synchrony between the fronto-parietal network and the local gamma
207 oscillations in sensory regions might underlie the incorporation of stimulus representations into
208 the focus of attention. The current framework shares many similarities with their inspiring
209 framework. The framework developed here is, however, very specific on how the modulation of
210 1) the local amplitude of alpha oscillations 2) the inter-areal phase-alignment and 3) how the
211 local interaction between the phase alpha oscillations and the power (not the phase) of feed-
212 forward gamma oscillations is involved in the selective routing of information in cognitive
213 networks. Furthermore, the current framework incorporates the phase coding scheme and
214 discusses the implementation of the model within the cortical layers. Finally, we attempt to
215 generalize the model by considering that other slow rhythms could implement the specific inter-
216 areal communication in other networks.

217

218 **Existing evidence and predictions for communication by nested oscillations**

219 Testing the proposed framework would require recordings from different regions in
220 humans or non-human primates in the context of a task as for instance done by Saalman et al.
221 (2012). In this study, monkeys were cued to covertly attend to one of six locations after which a
222 target array appeared. In the delay between cue and target, the allocation of covert attention was
223 associated with an increase in coherence between V4 and temporo-occipital areas. Moreover,
224 gamma coherence between V4 and TEO phase-locked to the alpha oscillations was observed.
225 These results support our framework by demonstrating that alpha-band coherence is in control of
226 the communication. While these findings provide first support for our framework, we will
227 outline set of more specific predictions applied to the visual system in the following:

228

229 *Prediction 1: Alpha oscillations are a consequence of internal control while gamma activity*
230 *reflects feedforward communication. Moreover, gamma activity is phase-locked to the alpha*
231 *oscillations.*

232 The framework predicts that alpha oscillations set up the communication between
233 relevant areas in a given task context. This idea implies that the phase and power of the alpha
234 oscillations are under internal control. The gamma oscillations phase-modulated by the alpha
235 oscillations will then reflect the information to be transferred in a feedforward manner.

236 Several recent papers have provided evidence in favor of slow frequency activity (alpha
237 and beta oscillations) reflecting feedback control and gamma activity reflecting feedforward
238 processing within the visual hierarchy (Bastos, et al. 2015, Jensen, et al. 2015, Michalareas, et al.
239 2016, van Kerkoerle, et al. 2014, von Stein, et al. 2000, see also Arnal, et al. 2011). Using
240 granger causality measures, they showed that alpha/beta oscillations in higher-order visual
241 regions impacted lower-order regions during an attention task while the reverse was observed for
242 gamma oscillations. Van Kerkoerle et al. (van Kerkoerle, et al. 2014) further demonstrated that
243 electrical stimulation of V1 induced an increase of gamma activity in V4 while stimulating V4
244 induced an increase of alpha oscillations in V1. The prediction regarding the control of alpha
245 oscillations goes beyond feedback control and we elaborate on many possibilities on where alpha
246 is generated in the section “Control of alpha oscillations in relation to cortical layers”. It is
247 important to note that gamma oscillations also can reflect feedback communication (Bastos, et al.
248 2015, Michalareas, et al. 2016; possibly controlled by alpha oscillations).

249 It has recently been shown that alpha and gamma activity interacts: gamma activity is
250 phase-coupled to alpha oscillations during rest and during stimulus anticipation and processing in
251 both monkeys and humans (Berman, et al. 2014, Bonnefond and Jensen 2015, Florin and Baillet
252 2015, Khan, et al. 2013, Spaak, et al. 2012, 2012, Voytek, et al. 2010). Two studies have
253 demonstrated that the higher the alpha activity, the lower the gamma activity at a specific phase
254 of alpha oscillations during rest in monkeys and during the retention period of a working
255 memory task in humans. This is in line with alpha activity being associated with pulses of
256 inhibition every ~100ms (Bonnefond and Jensen 2015, Spaak, et al. 2012). We propose that
257 gamma oscillations, nested within slow-oscillations serve to segment the neuronal
258 representations in time. According to this framework a neuronal representation is constituted by
259 a distributed firing pattern constrained to a given gamma cycle (Lisman and Idiart 1995). This
260 allows for several items to be multiplexed over a gamma cycle (see section “Exchange of phase
261 encoded information”).

262 However, there is currently a debate to whether gamma activity reflects oscillations or
263 whether they are a broad-band phenomenon devoid of rhythmicity, in particular for >80Hz
264 oscillations (Brunet, et al. 2014, Buzsaki and Schomburg 2015, Hermes, et al. 2014, Lachaux, et
265 al. 2005, Ray and Maunsell 2015). The broad-band activity (often called high-gamma activity or
266 even epsilon when > 80Hz) is likely to reflect a hash of neuronal spiking rather than oscillations.
267 However, it is possible that the 30-150 Hz activity is composed of both true oscillatory gamma
268 activity (Brunet, et al. 2014) and broad-band multi-unit activity (Manning, et al. 2009, Ray and
269 Maunsell 2011). Possibly, the 80-150Hz activity reflects the firing of neural populations, which
270 is phase-locked to gamma oscillations at lower frequencies (30-80Hz), as has been observed in
271 the rat hippocampus (Belluscio, et al. 2012).

272 This is an important issue as the CTC framework articulates a mechanistic role for the
273 phase of gamma oscillations such that the information can be transferred via inter-areal
274 synchrony. The nature of activities observed in different gamma frequencies needs therefore to
275 be further investigated using intracranial animal or human data.

276 In the present framework, the neuronal representation could contain both rhythmical
277 activity (cf e.g. section “Exchange of phase encoded information”) or broad-band activity devoid
278 of rhythmicity as the selectivity of the communication is subserved by an inter-areal
279 synchronization at lower frequencies, i.e. theta, alpha or beta.

280 Moreover, as pointed out above the modulation of gamma frequency by different visual
281 features (e.g contrast) is difficult to reconcile with the CTC framework. This would result in
282 different parts of an object being communicated at different frequencies in the visual hierarchy
283 preventing integration (but see Fries 2015). In the present framework, the gamma activity
284 generated by the different features of a stimulus would be represented at different phases of a
285 single alpha cycle in a multiplexing manner which then allows for integration. In future work, it
286 will be interesting to investigate whether alpha oscillations indeed serve to group and integrate
287 sensory input.

288

289 *Prediction 2: Alpha magnitude and inter-areal synchrony controls the transfer of information*
290 *carried by gamma oscillations.*

291 The framework assumes that alpha band phase-synchrony between A and C (see figure 2)
292 allows stimulus-driven gamma oscillations, modulated by the phase of the alpha oscillations, to
293 be transferred from A to C. Specifically we hypothesize that the synchrony of alpha oscillations
294 between relevant areas predicts inter-areal correlation or coherence of gamma oscillations.

295 While the inter-areal coherence observed in the alpha and gamma band during several
296 cognitive processes in rats, monkeys and humans (Bastos, et al. 2015, Bosman, et al. 2012,
297 Grothe, et al. 2012, Muller and Weisz 2012, Pollok, et al. 2007, Popov, et al. 2013, van
298 Kerkoerle, et al. 2014, Womelsdorf, et al. 2006) supports the notion that phase-synchronization
299 reflects information exchange, the role of cross-frequency interactions needs to be explored in
300 greater detail.

301 Our framework also predicts that the oscillatory dynamics can prevent the transfer of
302 information from region B to C. This is achieved by strong alpha oscillations in B which are in
303 asynchrony or anti-synchrony with oscillations in C. This results in the hypothesis that (i) alpha
304 power is strong in task-irrelevant areas (i.e. B) and (ii) there is a change in the phase relation
305 between task-irrelevant (B) and downstream regions (C). This might be reflected by anti-
306 synchrony or a decrease in synchrony (possibly due to a change in frequency in one of the pool).
307 The power increase and synchrony decrease will be associated with less inter-areal power-
308 correlation or coherence in the gamma band.

309 There is strong support for alpha magnitude increasing in task-irrelevant regions during
310 attention and memory tasks (Banerjee, et al. 2011, Bonnefond and Jensen 2012, Foxe, et al.
311 1998, Payne, et al. 2013, Snyder and Foxe 2010, Thut, et al. 2006, Worden, et al. 2000). For
312 instance, alpha oscillations have been shown to increase in the early visual regions in
313 anticipation of a distractor in working memory tasks (Bonnefond and Jensen 2012, Payne, et al.
314 2013). With respect to the inter-regional phase relationship, anti-synchrony ($\sim 180^\circ$ phase
315 difference) between parietal and frontal areas during an oculomotor, delayed-match-to-sample
316 task has been reported (Dotson, et al. 2014); however there are also findings demonstrating a
317 decrease in synchronization between visual regions when spatial attention is directed away (e.g.
318 Bastos, et al. 2015, Saalman, et al. 2012) .

319 Future investigations are required to identify when and where the mechanisms for
320 preventing information transfer are at play.

321

322 *Prediction 3: To allow communication between two specific pools of neurons, alpha oscillations*
323 *must be modulated locally on a fine spatial scale.*

324 The framework proposes that alpha oscillations are differently modulated in neuronal
325 pools A and B (see figure 1c). This should be the case even if the stimuli processed by A and B
326 are close to each other in retinotopic space. This results in the hypothesis that alpha oscillations
327 must be modulated locally.

328 However, while it is often assumed that alpha oscillations in the visual system are
329 modulated more globally (Thut, et al. 2006), recent monkey and human ECoG data provide
330 promising evidence that alpha oscillations can be modulated locally even at the receptive field
331 level. More precisely, these studies have shown that alpha oscillations increased (compared to
332 baseline) in the surround area of the stimulated receptive field in V1 (Harvey, et al. 2013, van
333 Kerkoerle, et al. 2014). This does not preclude the need for alpha oscillations to be modulated
334 more globally in the visual system in some situations such as during working memory
335 maintenance to protect against distractors (Bonnefond and Jensen 2012) or during alertness
336 (Sadaghiani and Kleinschmidt 2016).

337

338 **Communication based on nested oscillations could be a general mechanism throughout the**
339 **brain**

340 Thus far, we have focused on the coordinating role of alpha oscillations in the visual
341 network. Further modulation of the alpha activity related to functional inhibition has been
342 reported in the language network in humans (Wang, et al. 2012), in pre-frontal regions in the
343 monkey (Buschman, et al. 2012, Engel 2012, Jensen and Bonnefond 2013, Welberg 2013) and
344 even the hippocampus (Staresina, et al. 2016; but see below for a discussion regarding the
345 hippocampus). However, similar functional roles may be played by oscillations at other
346 frequencies, which have been shown to be prominent in other brain regions. For instance, there is
347 strong evidence for the coupling in the theta band between the hippocampus and other regions
348 such as prefrontal cortex, amygdala and the striatum (e.g. Backus, et al. 2016, Benchenane, et al.
349 2010, Kaplan, et al. 2014, Seidenbecher, et al. 2003, Staudigl and Hanslmayr 2013). Importantly
350 when theta and alpha activity are observed in intracranial recordings across species, gamma
351 power is typically found to be coupled to the phase of these oscillations (Belluscio, et al. 2012,
352 Canolty, et al. 2006, Canolty and Knight 2010, Colgin, et al. 2009, Hermes, et al. 2014, Jensen
353 and Colgin 2007, Spaak, et al. 2012, Voytek, et al. 2010). Thus, theta oscillations may play the
354 same functional role as the alpha oscillations in coordinating neuronal processing. Several
355 studies also points to theta being inhibitory (Mehta, et al. 2002). Given that theta oscillations in
356 the monkey hippocampus have been found to overlap in frequency with alpha oscillations
357 (Jutras, et al. 2013), it remains an exciting possibility that the visual cortex and the hippocampus
358 communicate via synchronization by means of these oscillation (Fell, et al. 2011). However, it is
359 debated whether the human theta rhythm is at ~3 Hz or in a higher band (Watrous, et al. 2013).
360 In case it would be at 3Hz, the interactions between the visual cortex and hippocampus could
361 then occur via cross-frequency coupling (Gu, et al. 2015). The involvement of theta oscillations
362 for coordinating the interactions between the striatum and the cortex during motor behavior in
363 rats has been revealed by von Nicolai et al. (2014). In line with the current model, they further
364 showed that the coordination of fast oscillations occurred via the coherent coupling of theta-
365 phase and high frequency amplitude.

366 Beta band oscillations might also play a role for coordinating the information flow by
367 means of cross-frequency coupling in e.g. the motor network (van Wijk, et al. 2016). Moreover,
368 some studies have reported attentional modulation of feedback-related beta oscillations in the

369 visual system (e.g. Bastos, et al. 2015, Kornblith, et al. 2016). It remains to be explored what the
370 functional differences between alpha and beta oscillations are. In particular, it will be important
371 to determine whether the beta activity in some cases result from non-linear addition of different
372 alpha generators in different cortical layers (Jones, et al. 2009). In line with this idea, laminar
373 recordings have only revealed modulation of alpha oscillations in the visual system during
374 attentional tasks (e.g. Bollimunta, et al. 2011, van Kerkoerle, et al. 2014) while EcoG recordings
375 have revealed modulation of beta oscillations (Bastos, et al. 2015).

376 **Exchange of phase encoded information**

377 Extensive work in the rat hippocampus has demonstrated that different information is
378 encoded at different phases of the theta cycle. In particular when a rat traverses a place field, the
379 phase of firing of the respective place cell advances with respect to theta-phase (O'Keefe and
380 Recce 1993). Several mechanisms have been proposed for how such a phase-organized code
381 might emerge (Burgess and O'Keefe 2011, Jensen and Lisman 1996, Lisman and Jensen 2013) .
382 In analogy, Jensen et al. (2014) recently proposed a model for how visual information might be
383 encoded along the phase of the alpha cycle. In the model, competing visual representations are
384 represented at different phase of the alpha cycle in order to resolve the bottleneck problem in the
385 visual system. Due to the convergence in the hierarchy of the visual ventral stream, two stimuli
386 (e.g. faces) might partly share the same neuronal representation in higher-order visual areas.
387 Jensen et al. proposed that the processing of these two stimuli is segmented in time by being
388 represented at different phases of the alpha cycle. The stronger the excitability of a given
389 representation the earlier it overcomes the inhibition as it ramps down within an alpha cycle.
390 This creates a temporal code organized according to excitability (Jensen, et al. 2014). As
391 proposed for the hippocampus (Colgin 2011, Jensen 2001), the exchange of phase-encoded
392 information can be achieved by phase-synchronizing the communicating networks (see figure 3).

393
394 Consider two representations associated with neurons in pool A and B. The excitability is
395 stronger for A than for B (figure 3a). Jensen et al. (2014) proposed that the neuronal firing
396 associated with each stimulus occurs at different phases of the alpha cycle. Moreover, A, B and
397 C would be synchronized in the alpha band and, as a consequence, this temporal organization
398 would then be transmitted to C (figure 3b). A possibility Jensen et al. (2014) did not discuss is

399 that the magnitude of the alpha oscillations in the two pools determines which stimulus is
400 processed first (figure 3c). In particular alpha power will be lower in pool A than in pool B, if the
401 stimulus processed by the former is more relevant/salient. As a consequence, the gamma burst
402 will occur earlier in A than in B due to the stronger alpha inhibition in the latter. Importantly,
403 alpha oscillations are still expected to be synchronous between the three pools. To date there is
404 little empirical evidence demonstrating that alpha phase organizes neuronal coding. There is
405 work in the delta, theta and beta band demonstrating phase-coding (Kayser, et al. 2009, Voytek,
406 et al. 2015, Watrous, et al. 2015). We call for future studies in which a phase-specific code is
407 investigated in the visual system in the alpha band.

408 **Control of alpha oscillations in relation to cortical layers**

409 The framework we propose assumes that alpha oscillations are internally controlled in
410 terms of phase and magnitude. We here discuss the mechanisms involved in the control. The
411 control serves to phase-synchronize the oscillations between different regions and to modulate
412 the degree of pulsed inhibition in order to allocate computational resources. A number of studies
413 have shown that alpha magnitude and phase can be modulated in anticipation of relevant or
414 irrelevant stimuli (Bonnefond and Jensen 2012, Foxe, et al. 1998, Foxe and Snyder 2011,
415 Samaha, et al. 2015, Thut, et al. 2006, but see van Diepen, et al. 2015) indicating that alpha
416 oscillatory activity is indeed under internal control. In this section, we discuss two
417 complementary mechanisms for this control, namely that alpha oscillations are controlled by
418 neocortical feedback connections or by the thalamus. We will discuss this in the context of layer-
419 specific computations.

420

421 *Feedback in relation to cortical layers and canonical microcircuits*

422 Interestingly, the pools of neurons involved in the feedforward and feedback pathways
423 are segregated in different cortical layers in the visual system (Markov, et al. 2014). The cortical
424 layers involved in the feedforward and feedback differ according to the hierarchical distance
425 between the connected brain regions (Barone, et al. 2000, Markov, et al. 2011, Markov, et al.
426 2014). In the case of the connections between V1 and V4, the feedforward pathway originates in
427 supragranular layers (L3B) in V1 and target granular layers (L4) and L3B in V4. The feedback
428 pathway from V4 originates in the supragranular layers L3A and infragranular layers L6 and

429 target supragranular layers L1-2/3A and infragranular layer L6 respectively in V1 (figure 4).
430 Interestingly, alpha activity has been observed mainly in both the supragranular and
431 infragranular layers of a given area, with a stronger power in the later (but see Haegens, et al.
432 2015) while gamma activity has been shown to be prominent in the granular and supragranular
433 layers (Bollimunta, et al. 2008, Bollimunta, et al. 2011, Buffalo, et al. 2011, Dougherty, et al.
434 2015, Maier, et al. 2011, Spaak, et al. 2012, van Kerkoerle, et al. 2014).

435 According to our model, supragranular and/or infragranular alpha oscillations should
436 exercise an inhibitory phasic influence on the granular and/or the supragranular gamma
437 magnitude (see Spaak, et al. 2012) (figure 4b).

438 As shown in figure 4, the feedback is diverging when originating in V4 and project back
439 to several V1 regions. This feedback needs to be selective, e.g. determining the alpha phase
440 synchronization from C to A, but not C to B. Moreover, local alpha magnitude in A and B should
441 be distinct with a higher alpha magnitude in B. We discuss below the putative role of different
442 neocortical and subcortical regions in modulating the local change in alpha magnitude and the
443 alpha synchronization between communicating areas.

444 It remains to be better understood how alpha and gamma oscillations are generated from
445 a physiological perspective and how their interaction is implemented at the level of the
446 microcircuit. The mechanisms generating gamma oscillations have been extensively reviewed in
447 Buzsáki and Wang (2012) but less is known about alpha oscillations. Alpha oscillations are
448 thought to involve inhibitory neurons to set-up pulses of inhibition every ~100ms. Somatostatin
449 cells engaged via lateral connections (Zhang, et al. 2014) or trans-laminar fast-spiking neurons
450 engaged by layer 6 neurons (Bortone, et al. 2014, Olsen, et al. 2012) or even layer 5 pyramidal
451 cells (Buchanan, et al. 2012) are strong candidates but further research is needed to evaluate their
452 behavior during alpha oscillations. Layer 1 interneurons might also be involved as dendrites from
453 layers 2/3A, 3B and 5 reach this layer (Markov, et al. 2014). Also, the role of lateral connections
454 (Angelucci and Bullier 2003, Tamura, et al. 2004, Wang, et al. 2000) as well as the role of the
455 thalamus (da Silva, et al. 1973, Lorincz, et al. 2009, Vijayan and Kopell 2012) needs to be
456 investigated.

457 The examples considered here concern the visual system. It has, however, been shown
458 that the laminar organization (e.g. cortical types can be granular, agranular or dysgranular) and
459 the connectivity between areas varies across networks (see e.g. Rempel-Clower and Barbas

460 2000). It will be important to consider these anatomical, but also functional, heterogeneities to
461 further determine whether the information is communicated by similar principles in these
462 different networks.

463 *Regions involved in the control of alpha*

464 Several studies have investigated the influences of the fronto-parietal network, i.e. the
465 frontal eye field (FEF) and the posterior parietal cortex, on activity of posterior regions
466 (Noudoost and Moore 2011, Squire, et al. 2013, Szczepanski, et al. 2010). The fronto-parietal
467 network includes a number of areas that are retinotopically organized, and it is engaged during
468 spatial attention, saccade planning and other cognitive and perceptual operations (Saygin and
469 Sereno 2008, Silver and Kastner 2009). The fronto-parietal network is directly and indirectly
470 (through the pulvinar) connected to visual regions. The FEF and parietal cortex have both been
471 shown to be associated with the control of alpha activity in posterior regions in humans
472 (Capotosto, et al. 2009, Marshall, et al. 2015, Sauseng, et al. 2011) potentially via the superior
473 longitudinal fasciculus (Marshall, et al. 2015). However, the role of the fronto-parietal network
474 for controlling alpha phase remains to be elucidated (but see Sauseng, et al. 2005).

475 Recently, Sadaghiani et al. (2016) further proposed that different cortical networks were
476 involved in controlling alpha oscillations. More specifically, they proposed that a network
477 including the dorsolateral prefrontal cortex, the rostromedial prefrontal cortex, the posterior
478 inferior parietal lobe, the paracingulate gyrus, and the mid-cingulate gyrus was involved in
479 controlling long-range alpha phase-locking associated with adaptive control while the dorsal
480 attention network (including intraparietal sulci, frontal eye fields, and middle temporal complex)
481 was associated with controlling the (dis-) engagement of regions via the control of local alpha
482 amplitude and as such with implementing selective attention.

483 Subcortical regions might also play a key role in modulating alpha activity. For instance,
484 the pulvinar is in a particularly well-suited anatomical position for controlling the
485 communication between posterior neocortical areas, since it is connected to a wide range of areas
486 in the visual hierarchy. More specifically, it is connected to neighboring cortical regions that are
487 themselves directly connected to each other (Saalmann and Kastner 2011, Saalmann, et al.
488 2012). Here, we consider two ways in which the pulvinar might influence the synchronization in
489 the alpha band between brain regions:

490 (1) The pulvinar might modulate the feedback originating from higher-order regions as it
491 targets layers 1 to 3 (L 1-3) of the lower-order area. In line with this idea, Purushothaman, et al.
492 (2012) showed that electrical stimulation of pulvinar neurons in anesthetized prosimian primates
493 resulted in boosting the firing of V1 neurons when stimuli were presented in the V1 neurons'
494 receptive fields, while it suppressed the neuronal activity when the stimuli were presented
495 outside the receptive field. As such, the stimulation mimicked the effects of attention. Following
496 the schema shown in Figure 4, we suggest that the pulvinar serves to synchronize C and A by
497 increasing the impact of the feedback connections arriving in L1-3. Likewise, the pulvinar might
498 decrease the activity in B reducing the synchrony between C and B. It is further possible that the
499 pulvinar increases the magnitude of alpha oscillations in B.

500 (2) The pulvinar might directly control the synchronization of alpha activity between two
501 areas, as it is connected to supragranular layers (L1-3) of the lower-order area (e.g. V1) and
502 granular layer (L4) of the higher-order area (e.g. V4) (Saalman and Kastner 2011). Although
503 alpha activity is thought to be particularly high in supragranular and infragranular layers, several
504 papers have also revealed the presence of an alpha generator in L4 (Bollimunta, et al. 2008,
505 Bollimunta, et al. 2011, Haegens, et al. 2015). It is thus possible that the pulvinar allows the
506 synchronization between L1-3 in a lower-order region and L4, which receives the feedforward
507 activity, in a higher-order region. In line with this idea, Saalman et al. (2012) demonstrated,
508 using a measure of Granger causality, that the pulvinar was driving the alpha-band
509 synchronization between V4 and TEO when attention was allocated at the receptive field of the
510 regions recorded. However, they did not observe an increase of the amplitude of alpha
511 oscillations in these cortical areas when attention was directed away from it (Kastner,
512 unpublished observations). Such amplitude change might occur only in V1. Therefore, they
513 could not investigate the influence of the pulvinar on a change in alpha amplitude as suggested in
514 the paragraph above. Interestingly, the pulvinar is also known to be connected to frontal areas
515 (Saalman and Kastner 2011). It is therefore possible that part of the influence of frontal areas
516 on the sensory cortex are mediated by the pulvinar. In summary, the mechanisms underlying the
517 influences of the pulvinar on alpha oscillations in the different cortical areas remain to be
518 understood. In addition to the pulvinar, interactions between the prefrontal cortex, the thalamic
519 reticular nucleus (TRN) and the lateral geniculate nucleus might also be involved in setting-up
520 alpha power increases in early visual regions. Recent papers have shown that the prefrontal

521 cortex directly influences TRN activity, thereby controlling thalamic sensory gain during
522 attention (Halassa, et al. 2011, Wimmer, et al. 2015).

523 Further investigations, such as exploring the task-specific laminar profiles of alpha
524 oscillations will be necessary to determine how the feedback activity from higher visual regions
525 and the different cortical and subcortical regions influence the power and the phase of alpha
526 activity across the visual network. In particular, it will be useful to determine how the phase
527 synchrony (both synchrony and anti-synchrony) is implemented. It is possible that the alpha
528 oscillations observed in different layers have distinct roles for coordinating communication. For
529 instance, alpha in supragranular layers might be involved in coordinating inter-areal
530 communication over long distances, while alpha in infragranular layers might be involved in
531 more local control of granular and supragranular gamma power. Indeed, it has been shown that
532 the supragranular layers exhibit a spatially-specific connectivity in both the feedforward and
533 feedback pathways, while the infragranular layers exhibit a more diffuse connectivity (Markov,
534 et al. 2014). The more diffuse connectivity might be related to the role of alpha oscillations in
535 the inhibition of all non-relevant cortical columns in a rather unspecific way while the spatially-
536 specific connectivity could be related to the communication of alpha activity within the relevant
537 pools of neurons.

538 **The role of saccades and slower rhythms**

539 In most electrophysiological studies in human and animals on attention and visual
540 perception, fixation is kept constant. However in daily life we make saccades several times per
541 second. Furthermore, even when fixating micro-saccades at 3 – 4Hz are apparent (Bosman, et al.
542 2009, Lowet, et al. 2016). In future work, it will be of great interest to investigate how saccade
543 relates to coupled alpha and gamma oscillations. One intriguing possibility is that the (micro-)
544 saccades are coordinated with alpha oscillations (Drewes and VanRullen 2011, Gaarder, et al.
545 1966). While spatial sampling could involve saccades, it could as well be implemented by
546 rhythmic shifts of spatial attention at slow frequency (Fiebelkorn, et al. 2013, Landau and Fries
547 2012, Landau, et al. 2015, Song, et al. 2014, see VanRullen 2016 for a review).

548 In the latest version of the CTC, Fries (2015) further develops the idea that the cross-
549 frequency coupling between theta and gamma oscillations implements visual attentional
550 sampling (Bosman, et al. 2009, Bosman, et al. 2012). The sampling role of theta oscillations in

551 the visual system proposed by Fries (2015), which seems to be transmitted in the feedforward
552 direction (Bastos et al. 2015, van Kerkoerle et al. 2014), is different from the role of alpha
553 oscillations we propose. Specifically we suggest that the role of alpha oscillations is to
554 implement inter-areal communication by modulating inter-areal phase synchronization and the
555 local magnitude. However, recent results suggest that the theta and alpha rhythms could interact.
556 Song et al. (2014) presented interesting results showing that the behavioral performances (in
557 terms of reaction time) in an attention task (discrimination of a square or a circle) was modulated
558 in the alpha-range, but alternated between the cued and uncued side at a theta rhythm (3-4Hz),
559 i.e. the behavior exhibited a theta-alpha coupling.

560 Further work is needed to understand in which situations such slower rhythms are
561 required and how they interact with the alpha and gamma oscillations in relation to (micro-)
562 saccades. Finally, it is important to develop a model integrating the feedforward sweep that is
563 evoked by saccades and microsaccades (Gaarder, et al. 1966, Ito, et al. 2013).

564 **Conclusion**

565 In this paper, we have proposed a framework for flexible communication between
566 interconnected nodes in the brain based on the coupling between slow oscillations in the
567 theta/alpha band and activity in the gamma band. Testing the framework will require integrating
568 animal and human research in order to relate spiking to behavior from a mechanistic perspective.
569 This will allow for elucidating how representational specific information is exchanged between
570 brain regions. Finally, it needs to be understood how these cross-frequency interactions are
571 internally controlled. Of particular interest is the involvement of the thalamus in coordinating
572 oscillatory activity between regions.

573 **References**

- 574 Akam, T. and Kullmann, D. M. (2014) Oscillatory multiplexing of population codes for selective
575 communication in the mammalian brain. *Nat Rev Neurosci* 15:111-22
- 576 Angelucci, A. and Bullier, J. (2003) Reaching beyond the classical receptive field of VI neurons: horizontal
577 or feedback axons? *Journal of Physiology-Paris* 97:141-154
- 578 Arnal, L. H., Wyart, V. and Giraud, A. L. (2011) Transitions in neural oscillations reflect prediction errors
579 generated in audiovisual speech. *Nat Neurosci* 14:797-801
- 580 Backus, Alexander R., Schoffelen, J.-M., Szebényi, S., Hanslmayr, S. and Doeller, Christian F. (2016)
581 Hippocampal-Prefrontal Theta Oscillations Support Memory Integration. *Current Biology*
582 26:450-457

- 583 Banerjee, S., Snyder, A. C., Molholm, S. and Foxe, J. J. (2011) Oscillatory alpha-band mechanisms and the
584 deployment of spatial attention to anticipated auditory and visual target locations: supramodal
585 or sensory-specific control mechanisms? *J Neurosci* 31:9923-32
- 586 Barone, P., Batardiere, A., Knoblauch, K. and Kennedy, H. (2000) Laminar distribution of neurons in
587 extrastriate areas projecting to visual areas V1 and V4 correlates with the hierarchical rank and
588 indicates the operation of a distance rule. *J Neurosci* 20:3263-81
- 589 Bastos, A. M., Vezoli, J., Bosman, C. A., Schoffelen, J. M., Oostenveld, R., Dowdall, J. R., De Weerd, P.,
590 Kennedy, H. and Fries, P. (2015) Visual Areas Exert Feedforward and Feedback Influences
591 through Distinct Frequency Channels. *Neuron* 85:390-401
- 592 Bastos, A. M., Vezoli, J. and Fries, P. (2015) Communication through coherence with inter-areal delays.
593 *Curr Opin Neurobiol* 31:173-80
- 594 Belluscio, M. A., Mizuseki, K., Schmidt, R., Kempter, R. and Buzsaki, G. (2012) Cross-frequency phase-
595 phase coupling between theta and gamma oscillations in the hippocampus. *J Neurosci* 32:423-
596 35
- 597 Benchenane, K., Peyrache, A., Khamassi, M., Tierney, P. L., Gioanni, Y., Battaglia, F. P. and Wiener, S. I.
598 (2010) Coherent theta oscillations and reorganization of spike timing in the hippocampal-
599 prefrontal network upon learning. *Neuron* 66:921-36
- 600 Berman, J., Liu, S., Bloy, L., Blaskey, L., Roberts, T. P. and Edgar, J. C. (2014) Alpha-to-Gamma Phase-
601 amplitude Coupling Methods and Application to Autism Spectrum Disorder. *Brain Connect*
- 602 Bollimunta, A., Chen, Y., Schroeder, C. E. and Ding, M. (2008) Neuronal mechanisms of cortical alpha
603 oscillations in awake-behaving macaques. *The Journal of neuroscience : the official journal of*
604 *the Society for Neuroscience* 28:9976-88
- 605 Bollimunta, A., Mo, J., Schroeder, C. E. and Ding, M. (2011) Neuronal mechanisms and attentional
606 modulation of corticothalamic alpha oscillations. *The Journal of neuroscience : the official*
607 *journal of the Society for Neuroscience* 31:4935-43
- 608 Bonnefond, M. and Jensen, O. (2012) Alpha oscillations serve to protect working memory maintenance
609 against anticipated distracters. *Curr Biol* 22:1969-74
- 610 Bonnefond, M. and Jensen, O. (2013) The role of gamma and alpha oscillations for blocking out
611 distraction. *Communicative & Integrative Biology* 6:e22702
- 612 Bonnefond, M. and Jensen, O. (2015) Gamma activity coupled to alpha phase as a mechanism for top-
613 down controlled gating. *PLoS One* 10:e0128667
- 614 Bortone, D. S., Olsen, S. R. and Scanziani, M. (2014) Translaminar inhibitory cells recruited by layer 6
615 corticothalamic neurons suppress visual cortex. *Neuron* 82:474-85
- 616 Bosman, C. A., Womelsdorf, T., Desimone, R. and Fries, P. (2009) A microsaccadic rhythm modulates
617 gamma-band synchronization and behavior. *J Neurosci* 29:9471-80
- 618 Bosman, C. A., Schoffelen, J. M., Brunet, N., Oostenveld, R., Bastos, A. M., Womelsdorf, T., Rubehn, B.,
619 Stieglitz, T., De Weerd, P. and Fries, P. (2012) Attentional stimulus selection through selective
620 synchronization between monkey visual areas. *Neuron* 75:875-88
- 621 Brunet, N., Vinck, M., Bosman, C. A., Singer, W. and Fries, P. (2014) Gamma or no gamma, that is the
622 question. *Trends Cogn Sci* 18:507-9
- 623 Buchanan, K. A., Blackman, A. V., Moreau, A. W., Elgar, D., Costa, R. P., Lalanne, T., Tudor Jones, A. A.,
624 Oyrer, J. and Sjöström, P. J. (2012) Target-specific expression of presynaptic NMDA receptors in
625 neocortical microcircuits. *Neuron* 75:451-66
- 626 Buffalo, E. A., Fries, P., Landman, R., Buschman, T. J. and Desimone, R. (2011) Laminar differences in
627 gamma and alpha coherence in the ventral stream. *Proceedings of the National Academy of*
628 *Sciences of the United States of America* 108:11262-7
- 629 Burgess, N. and O'Keefe, J. (2011) Models of place and grid cell firing and theta rhythmicity. *Current*
630 *Opinion in Neurobiology* 21:734-744

- 631 Busch, N. A. and VanRullen, R. (2010) Spontaneous EEG oscillations reveal periodic sampling of visual
632 attention. *Proc Natl Acad Sci U S A* 107:16048-53
- 633 Buschman, T. J., Denovellis, E. L., Diogo, C., Bullock, D. and Miller, E. K. (2012) Synchronous oscillatory
634 neural ensembles for rules in the prefrontal cortex. *Neuron* 76:838-46
- 635 Buzsáki, G. and Schomburg, E. W. (2015) What does gamma coherence tell us about inter-regional
636 neural communication? *Nat Neurosci* 18:484-9
- 637 Buzsáki, G. and Wang, X.-J. (2012) Mechanisms of Gamma Oscillations. *Annual review of neuroscience*
638 35:203-225
- 639 Canolty, R. T., Edwards, E., Dalal, S. S., Soltani, M., Nagarajan, S. S., Kirsch, H. E., Berger, M. S., Barbaro,
640 N. M. and Knight, R. T. (2006) High gamma power is phase-locked to theta oscillations in human
641 neocortex. *Science* 313:1626-8
- 642 Canolty, R. T. and Knight, R. T. (2010) The functional role of cross-frequency coupling. *Trends in cognitive*
643 *sciences* 14:506-515
- 644 Capilla, A., Schoffelen, J. M., Paterson, G., Thut, G. and Gross, J. (2014) Dissociated alpha-band
645 modulations in the dorsal and ventral visual pathways in visuospatial attention and perception.
646 *Cereb Cortex* 24:550-61
- 647 Capotosto, P., Babiloni, C., Romani, G. L. and Corbetta, M. (2009) Frontoparietal cortex controls spatial
648 attention through modulation of anticipatory alpha rhythms. *J Neurosci* 29:5863-72
- 649 Colgin, L. L., Denninger, T., Fyhn, M., Hafting, T., Bonnevie, T., Jensen, O., Moser, M. B. and Moser, E. I.
650 (2009) Frequency of gamma oscillations routes flow of information in the hippocampus. *Nature*
651 462:353-7
- 652 Colgin, L. L. (2011) Oscillations and hippocampal–prefrontal synchrony. *Current Opinion in Neurobiology*
653 21:467-474
- 654 da Silva, F. H., van Lierop, T. H., Schrijer, C. F. and van Leeuwen, W. S. (1973) Organization of thalamic
655 and cortical alpha rhythms: spectra and coherences. *Electroencephalogr Clin Neurophysiol*
656 35:627-39
- 657 Dotson, N. M., Salazar, R. F. and Gray, C. M. (2014) Frontoparietal Correlation Dynamics Reveal Interplay
658 between Integration and Segregation during Visual Working Memory. *The Journal of*
659 *Neuroscience* 34:13600-13613
- 660 Dougherty, K., Cox, M. A., Ninomiya, T., Leopold, D. A. and Maier, A. (2015) Ongoing Alpha Activity in V1
661 Regulates Visually Driven Spiking Responses. *Cerebral Cortex*
- 662 Drewes, J. and VanRullen, R. (2011) This is the rhythm of your eyes: the phase of ongoing
663 electroencephalogram oscillations modulates saccadic reaction time. *J Neurosci* 31:4698-708
- 664 Engel, A. K. (2012) Rules got rhythm. *Neuron* 76:673-6
- 665 Fell, J., Ludowig, E., Staresina, B. P., Wagner, T., Kranz, T., Elger, C. E. and Axmacher, N. (2011) Medial
666 temporal theta/alpha power enhancement precedes successful memory encoding: evidence
667 based on intracranial EEG. *J Neurosci* 31:5392-7
- 668 Fiebelkorn, I. C., Saalman, Y. B. and Kastner, S. (2013) Rhythmic sampling within and between objects
669 despite sustained attention at a cued location. *Curr Biol* 23:2553-8
- 670 Florin, E. and Baillet, S. (2015) The brain's resting-state activity is shaped by synchronized cross-
671 frequency coupling of neural oscillations. *Neuroimage* 111:26-35
- 672 Foxe, J. J., Simpson, G. V. and Ahlfors, S. P. (1998) Parieto-occipital approximately 10 Hz activity reflects
673 anticipatory state of visual attention mechanisms. *Neuroreport* 9:3929-33
- 674 Foxe, J. J. and Snyder, A. C. (2011) The Role of Alpha-Band Brain Oscillations as a Sensory Suppression
675 Mechanism during Selective Attention. *Front Psychol* 2:154
- 676 Foxe, J. J. and Snyder, A. C. (2011) The Role of Alpha-Band Brain Oscillations as a Sensory Suppression
677 Mechanism during Selective Attention. *Frontiers in psychology* 2:154

- 678 Fries, P. (2005) A mechanism for cognitive dynamics: neuronal communication through neuronal
679 coherence. *Trends Cogn Sci* 9:474-80
- 680 Fries, P. (2009) Neuronal gamma-band synchronization as a fundamental process in cortical
681 computation. *Annu Rev Neurosci* 32:209-24
- 682 Fries, P. (2015) Rhythms for Cognition: Communication through Coherence. *Neuron* 88:220-35
- 683 Gaarder, K., Koresko, R. and Kropfl, W. (1966) The phasic relation of a component of alpha rhythm to
684 fixation saccadic eye movements. *Electroencephalogr Clin Neurophysiol* 21:544-51
- 685 Grothe, I., Neitzel, S. D., Mandon, S. and Kreiter, A. K. (2012) Switching neuronal inputs by differential
686 modulations of gamma-band phase-coherence. *J Neurosci* 32:16172-80
- 687 Gu, B.-M., van Rijn, H. and Meck, W. H. (2015) Oscillatory multiplexing of neural population codes for
688 interval timing and working memory. *Neuroscience & Biobehavioral Reviews* 48:160-185
- 689 Hadjipapas, A., Lowet, E., Roberts, M. J., Peter, A. and De Weerd, P. (2015) Parametric variation of
690 gamma frequency and power with luminance contrast: A comparative study of human MEG and
691 monkey LFP and spike responses. *Neuroimage* 112:327-40
- 692 Haegens, S., Osipova, D., Oostenveld, R. and Jensen, O. (2010) Somatosensory working memory
693 performance in humans depends on both engagement and disengagement of regions in a
694 distributed network. *Hum Brain Mapp* 31:26-35
- 695 Haegens, S., Handel, B. F. and Jensen, O. (2011) Top-down controlled alpha band activity in
696 somatosensory areas determines behavioral performance in a discrimination task. *J Neurosci*
697 31:5197-204
- 698 Haegens, S., Nacher, V., Luna, R., Romo, R. and Jensen, O. (2011) alpha-Oscillations in the monkey
699 sensorimotor network influence discrimination performance by rhythmical inhibition of
700 neuronal spiking. *Proc Natl Acad Sci U S A* 108:19377-82
- 701 Haegens, S., Luther, L. and Jensen, O. (2012) Somatosensory anticipatory alpha activity increases to
702 suppress distracting input. *Journal of cognitive neuroscience* 24:677-85
- 703 Haegens, S., Barczak, A., Musacchia, G., Lipton, M. L., Mehta, A. D., Lakatos, P. and Schroeder, C. E.
704 (2015) Laminar Profile and Physiology of the alpha Rhythm in Primary Visual, Auditory, and
705 Somatosensory Regions of Neocortex. *J Neurosci* 35:14341-52
- 706 Halassa, M. M., Siegle, J. H., Ritt, J. T., Ting, J. T., Feng, G. and Moore, C. I. (2011) Selective optical drive
707 of thalamic reticular nucleus generates thalamic bursts and cortical spindles. *Nat Neurosci*
708 14:1118-20
- 709 Handel, B. F., Haarmeier, T. and Jensen, O. (2011) Alpha oscillations correlate with the successful
710 inhibition of unattended stimuli. *J Cogn Neurosci* 23:2494-502
- 711 Harvey, B. M., Vansteensel, M. J., Ferrier, C. H., Petridou, N., Zuiderbaan, W., Aarnoutse, E. J., Bleichner,
712 M. G., Dijkerman, H. C., van Zandvoort, M. J., Leijten, F. S., Ramsey, N. F. and Dumoulin, S. O.
713 (2013) Frequency specific spatial interactions in human electrocorticography: V1 alpha
714 oscillations reflect surround suppression. *Neuroimage* 65:424-32
- 715 Hermes, D., Miller, K. J., Vansteensel, M. J., Edwards, E., Ferrier, C. H., Bleichner, M. G., van Rijen, P. C.,
716 Aarnoutse, E. J. and Ramsey, N. F. (2014) Cortical theta wanes for language. *Neuroimage* 85 Pt
717 2:738-48
- 718 Hermes, D., Miller, K. J., Wandell, B. A. and Winawer, J. (2014) Stimulus Dependence of Gamma
719 Oscillations in Human Visual Cortex. *Cereb Cortex*
- 720 Histed, M. H. and Maunsell, J. H. (2014) Cortical neural populations can guide behavior by integrating
721 inputs linearly, independent of synchrony. *Proc Natl Acad Sci U S A* 111:E178-87
- 722 Hyafil, A., Giraud, A. L., Fontolan, L. and Gutkin, B. (2015) Neural Cross-Frequency Coupling: Connecting
723 Architectures, Mechanisms, and Functions. *Trends Neurosci* 38:725-40
- 724 Ito, J., Maldonado, P. and Grun, S. (2013) Cross-frequency interaction of the eye-movement related LFP
725 signals in V1 of freely viewing monkeys. *Front Syst Neurosci* 7:1

- 726 Jensen, O. and Lisman, J. E. (1996) Theta/gamma networks with slow NMDA channels learn sequences
727 and encode episodic memory: role of NMDA channels in recall. *Learn Mem* 3:264-78
- 728 Jensen, O. (2001) Information transfer between rhythmically coupled networks: reading the
729 hippocampal phase code. *Neural Comput* 13:2743-61
- 730 Jensen, O. and Colgin, L. L. (2007) Cross-frequency coupling between neuronal oscillations. *Trends Cogn*
731 *Sci* 11:267-9
- 732 Jensen, O. and Mazaheri, A. (2010) Shaping functional architecture by oscillatory alpha activity: gating by
733 inhibition. *Front Hum Neurosci* 4:186
- 734 Jensen, O., Bonnefond, M. and VanRullen, R. (2012) An oscillatory mechanism for prioritizing salient
735 unattended stimuli. *Trends Cogn Sci* 16:200-6
- 736 Jensen, O. and Bonnefond, M. (2013) Prefrontal alpha- and beta-band oscillations are involved in rule
737 selection. *Trends Cogn Sci* 17:10-2
- 738 Jensen, O., Gips, B., Bergmann, T. O. and Bonnefond, M. (2014) Temporal coding organized by coupled
739 alpha and gamma oscillations prioritize visual processing. *Trends Neurosci* 37:357-69
- 740 Jensen, O., Bonnefond, M., Marshall, T. R. and Tiesinga, P. (2015) Oscillatory mechanisms of feedforward
741 and feedback visual processing. *Trends Neurosci* 38:192-4
- 742 Jones, S. R., Pritchett, D. L., Sikora, M. A., Stufflebeam, S. M., Hämäläinen, M. and Moore, C. I. (2009)
743 Quantitative Analysis and Biophysically Realistic Neural Modeling of the MEG Mu Rhythm:
744 Rhythmogenesis and Modulation of Sensory-Evoked Responses. *Journal of Neurophysiology*
745 102:3554-3572
- 746 Jutras, M. J., Fries, P. and Buffalo, E. A. (2013) Oscillatory activity in the monkey hippocampus during
747 visual exploration and memory formation. *Proc Natl Acad Sci U S A* 110:13144-9
- 748 Kaplan, R., Bush, D., Bonnefond, M., Bandettini, P. A., Barnes, G. R., Doeller, C. F. and Burgess, N. (2014)
749 Medial prefrontal theta phase coupling during spatial memory retrieval. *Hippocampus* 24:656-
750 65
- 751 Kayser, C., Montemurro, M. A., Logothetis, N. K. and Panzeri, S. (2009) Spike-phase coding boosts and
752 stabilizes information carried by spatial and temporal spike patterns. *Neuron* 61:597-608
- 753 Khan, S., Gramfort, A., Shetty, N. R., Kitzbichler, M. G., Ganesan, S., Moran, J. M., Lee, S. M., Gabrieli, J.
754 D., Tager-Flusberg, H. B., Joseph, R. M., Herbert, M. R., Hamalainen, M. S. and Kenet, T. (2013)
755 Local and long-range functional connectivity is reduced in concert in autism spectrum disorders.
756 *Proc Natl Acad Sci U S A* 110:3107-12
- 757 Klimesch, W., Sauseng, P. and Hanslmayr, S. (2007) EEG alpha oscillations: the inhibition-timing
758 hypothesis. *Brain Res Rev* 53:63-88
- 759 Kornblith, S., Buschman, T. J. and Miller, E. K. (2016) Stimulus Load and Oscillatory Activity in Higher
760 Cortex. *Cereb Cortex* 26:3772-84
- 761 Lachaux, J. P., George, N., Tallon-Baudry, C., Martinerie, J., Hugueville, L., Minotti, L., Kahane, P. and
762 Renault, B. (2005) The many faces of the gamma band response to complex visual stimuli.
763 *Neuroimage* 25:491-501
- 764 Lakatos, P., Shah, A. S., Knuth, K. H., Ulbert, I., Karmos, G. and Schroeder, C. E. (2005) An oscillatory
765 hierarchy controlling neuronal excitability and stimulus processing in the auditory cortex. *J*
766 *Neurophysiol* 94:1904-11
- 767 Landau, A. N. and Fries, P. (2012) Attention samples stimuli rhythmically. *Curr Biol* 22:1000-4
- 768 Landau, A. N., Schreyer, H. M., van Pelt, S. and Fries, P. (2015) Distributed Attention Is Implemented
769 through Theta-Rhythmic Gamma Modulation. *Curr Biol* 25:2332-7
- 770 Larkum, M. (2013) A cellular mechanism for cortical associations: an organizing principle for the cerebral
771 cortex. *Trends Neurosci* 36:141-51
- 772 Lee, J. H., Whittington, M. A. and Kopell, N. J. (2013) Top-down beta rhythms support selective attention
773 via interlaminar interaction: a model. *PLoS Comput Biol* 9:e1003164

- 774 Lisman, J. E. and Idiart, M. A. (1995) Storage of 7 +/- 2 short-term memories in oscillatory subcycles.
775 *Science* 267:1512-5
- 776 Lisman, John E. and Jensen, O. (2013) The Theta-Gamma Neural Code. *Neuron* 77:1002-1016
- 777 Lorincz, M. L., Kekesi, K. A., Juhász, G., Crunelli, V. and Hughes, S. W. (2009) Temporal framing of
778 thalamic relay-mode firing by phasic inhibition during the alpha rhythm. *Neuron* 63:683-96
- 779 Lowet, E., Roberts, M. J., Bosman, C. A., Fries, P. and De Weerd, P. (2016) Areas V1 and V2 show
780 microsaccade-related 3-4-Hz covariation in gamma power and frequency. *Eur J Neurosci*
781 43:1286-96
- 782 Maier, A., Aura, C. J. and Leopold, D. A. (2011) Infragranular sources of sustained local field potential
783 responses in macaque primary visual cortex. *J Neurosci* 31:1971-80
- 784 Manning, J. R., Jacobs, J., Fried, I. and Kahana, M. J. (2009) Broadband shifts in local field potential
785 power spectra are correlated with single-neuron spiking in humans. *J Neurosci* 29:13613-20
- 786 Markov, N. T., Misery, P., Falchier, A., Lamy, C., Vezoli, J., Quilodran, R., Gariel, M. A., Giroud, P., Ercsey-
787 Ravasz, M., Pilaz, L. J., Huissoud, C., Barone, P., Dehay, C., Toroczka, Z., Van Essen, D. C.,
788 Kennedy, H. and Knoblauch, K. (2011) Weight consistency specifies regularities of macaque
789 cortical networks. *Cereb Cortex* 21:1254-72
- 790 Markov, N. T., Ercsey-Ravasz, M. M., Ribeiro Gomes, A. R., Lamy, C., Magrou, L., Vezoli, J., Misery, P.,
791 Falchier, A., Quilodran, R., Gariel, M. A., Sallet, J., Gamanut, R., Huissoud, C., Clavagnier, S.,
792 Giroud, P., Sappey-Marinier, D., Barone, P., Dehay, C., Toroczka, Z., Knoblauch, K., Van Essen, D.
793 C. and Kennedy, H. (2014) A weighted and directed interareal connectivity matrix for macaque
794 cerebral cortex. *Cereb Cortex* 24:17-36
- 795 Markov, N. T., Vezoli, J., Chameau, P., Falchier, A., Quilodran, R., Huissoud, C., Lamy, C., Misery, P.,
796 Giroud, P., Ullman, S., Barone, P., Dehay, C., Knoblauch, K. and Kennedy, H. (2014) Anatomy of
797 hierarchy: feedforward and feedback pathways in macaque visual cortex. *J Comp Neurol*
798 522:225-59
- 799 Marshall, T. R., Bergmann, T. O. and Jensen, O. (2015) Frontoparietal Structural Connectivity Mediates
800 the Top-Down Control of Neuronal Synchronization Associated with Selective Attention. *PLoS*
801 *Biol* 13:e1002272
- 802 Marshall, T. R., O'Shea, J., Jensen, O. and Bergmann, T. O. (2015) Frontal eye fields control attentional
803 modulation of alpha and gamma oscillations in contralateral occipitoparietal cortex. *J Neurosci*
804 35:1638-47
- 805 Meeuwissen, E. B., Takashima, A., Fernandez, G. and Jensen, O. (2010) Increase in posterior alpha
806 activity during rehearsal predicts successful long-term memory formation of word sequences.
807 *Hum Brain Mapp*
- 808 Mehta, M. R., Lee, A. K. and Wilson, M. A. (2002) Role of experience and oscillations in transforming a
809 rate code into a temporal code. *Nature* 417:741-6
- 810 Michalareas, G., Vezoli, J., van Pelt, S., Schoffelen, J. M., Kennedy, H. and Fries, P. (2016) Alpha-Beta and
811 Gamma Rhythms Subserve Feedback and Feedforward Influences among Human Visual Cortical
812 Areas. *Neuron*
- 813 Mo, J., Schroeder, C. E. and Ding, M. (2011) Attentional modulation of alpha oscillations in macaque
814 inferotemporal cortex. *J Neurosci* 31:878-82
- 815 Muller, N. and Weisz, N. (2012) Lateralized auditory cortical alpha band activity and interregional
816 connectivity pattern reflect anticipation of target sounds. *Cereb Cortex* 22:1604-13
- 817 Myers, N. E., Stokes, M. G., Walther, L. and Nobre, A. C. (2014) Oscillatory brain state predicts variability
818 in working memory. *J Neurosci* 34:7735-43
- 819 Noudoost, B. and Moore, T. (2011) Control of visual cortical signals by prefrontal dopamine. *Nature*
820 474:372-5

- 821 O'Keefe, J. and Recce, M. L. (1993) Phase relationship between hippocampal place units and the EEG
822 theta rhythm. *Hippocampus* 3:317-30
- 823 Olsen, S. R., Bortone, D. S., Adesnik, H. and Scanziani, M. (2012) Gain control by layer six in cortical
824 circuits of vision. *Nature* 483:47-52
- 825 Palva, S. and Palva, J. M. (2007) New vistas for alpha-frequency band oscillations. *Trends Neurosci*
826 30:150-8
- 827 Palva, S. and Palva, J. M. (2011) Functional roles of alpha-band phase synchronization in local and large-
828 scale cortical networks. *Front Psychol* 2:204
- 829 Payne, L., Guillory, S. and Sekuler, R. (2013) Attention-modulated alpha-band oscillations protect against
830 intrusion of irrelevant information. *Journal of cognitive neuroscience* 25:1463-76
- 831 Pollok, B., Butz, M., Gross, J. and Schnitzler, A. (2007) Intercerebellar coupling contributes to bimanual
832 coordination. *Journal of cognitive neuroscience* 19:704-19
- 833 Popov, T., Miller, G. A., Rockstroh, B. and Weisz, N. (2013) Modulation of alpha power and functional
834 connectivity during facial affect recognition. *J Neurosci* 33:6018-26
- 835 Purushothaman, G., Marion, R., Li, K. and Casagrande, V. A. (2012) Gating and control of primary visual
836 cortex by pulvinar. *Nat Neurosci* 15:905-12
- 837 Ray, S. and Maunsell, J. H. (2010) Differences in gamma frequencies across visual cortex restrict their
838 possible use in computation. *Neuron* 67:885-96
- 839 Ray, S. and Maunsell, J. H. R. (2011) Different Origins of Gamma Rhythm and High-Gamma Activity in
840 Macaque Visual Cortex. *PLoS Biol* 9:e1000610
- 841 Ray, S. and Maunsell, J. H. (2015) Do gamma oscillations play a role in cerebral cortex? *Trends Cogn Sci*
842 19:78-85
- 843 Rempel-Clower, N. L. and Barbas, H. (2000) The laminar pattern of connections between prefrontal and
844 anterior temporal cortices in the Rhesus monkey is related to cortical structure and function.
845 *Cereb Cortex* 10:851-65
- 846 Rolls, E. T., Webb, T. J. and Deco, G. (2012) Communication before coherence. *Eur J Neurosci* 36:2689-
847 709
- 848 Saalmann, Y. B. and Kastner, S. (2011) Cognitive and perceptual functions of the visual thalamus. *Neuron*
849 71:209-23
- 850 Saalmann, Y. B., Pinsk, M. A., Wang, L., Li, X. and Kastner, S. (2012) The Pulvinar Regulates Information
851 Transmission Between Cortical Areas Based on Attention Demands. *Science* 337:753-756
- 852 Sadaghiani, S. and Kleinschmidt, A. (2016) Brain Networks and alpha-Oscillations: Structural and
853 Functional Foundations of Cognitive Control. *Trends Cogn Sci* 20:805-817
- 854 Salinas, E. and Sejnowski, T. J. (2001) Correlated neuronal activity and the flow of neural information.
855 *Nat Rev Neurosci* 2:539-550
- 856 Samaha, J., Bauer, P., Cimaroli, S. and Postle, B. R. (2015) Top-down control of the phase of alpha-band
857 oscillations as a mechanism for temporal prediction. *Proc Natl Acad Sci U S A* 112:8439-44
- 858 Sauseng, P., Klimesch, W., Schabus, M. and Doppelmayr, M. (2005) Fronto-parietal EEG coherence in
859 theta and upper alpha reflect central executive functions of working memory. *Int J*
860 *Psychophysiol* 57:97-103
- 861 Sauseng, P., Feldheim, J. F., Freunberger, R. and Hummel, F. C. (2011) Right Prefrontal TMS Disrupts
862 Interregional Anticipatory EEG Alpha Activity during Shifting of Visuospatial Attention. *Front*
863 *Psychol* 2:241
- 864 Saygin, A. P. and Sereno, M. I. (2008) Retinotopy and attention in human occipital, temporal, parietal,
865 and frontal cortex. *Cereb Cortex* 18:2158-68
- 866 Schroeder, C. E. and Lakatos, P. (2009) Low-frequency neuronal oscillations as instruments of sensory
867 selection. *Trends Neurosci* 32:9-18

- 868 Seidenbecher, T., Laxmi, T. R., Stork, O. and Pape, H. C. (2003) Amygdalar and hippocampal theta rhythm
869 synchronization during fear memory retrieval. *Science* 301:846-50
- 870 Sherman, M. T., Kanai, R., Seth, A. K. and VanRullen, R. (2016) Rhythmic Influence of Top-Down
871 Perceptual Priors in the Phase of Prestimulus Occipital Alpha Oscillations. *J Cogn Neurosci*
872 28:1318-30
- 873 Siebenhühner, F., Wang, S. H., Palva, J. M. and Palva, S. (2016) Cross-frequency synchronization
874 connects networks of fast and slow oscillations during visual working memory maintenance.
875 *eLife* 5:e13451
- 876 Silver, M. A. and Kastner, S. (2009) Topographic maps in human frontal and parietal cortex. *Trends Cogn*
877 *Sci* 13:488-95
- 878 Snyder, A. C. and Foxe, J. J. (2010) Anticipatory attentional suppression of visual features indexed by
879 oscillatory alpha-band power increases: a high-density electrical mapping study. *J Neurosci*
880 30:4024-32
- 881 Song, K., Meng, M., Chen, L., Zhou, K. and Luo, H. (2014) Behavioral oscillations in attention: rhythmic
882 alpha pulses mediated through theta band. *J Neurosci* 34:4837-44
- 883 Spaak, E., Bonnefond, M., Maier, A., Leopold, D. A. and Jensen, O. (2012) Layer-Specific Entrainment of
884 Gamma-Band Neural Activity by the Alpha Rhythm in Monkey Visual Cortex. *Current biology : CB*
- 885 Spaak, E., Bonnefond, M., Maier, A., Leopold, D. A. and Jensen, O. (2012) Layer-specific entrainment of
886 gamma-band neural activity by the alpha rhythm in monkey visual cortex. *Curr Biol* 22:2313-8
- 887 Squire, R. F., Noudoost, B., Schafer, R. J. and Moore, T. (2013) Prefrontal contributions to visual selective
888 attention. *Annu Rev Neurosci* 36:451-66
- 889 Staresina, B. P., Michelmann, S., Bonnefond, M., Jensen, O., Axmacher, N. and Fell, J. (2016)
890 Hippocampal pattern completion is linked to gamma power increases and alpha power
891 decreases during recollection. *Elife* 5:
- 892 Staudigl, T. and Hanslmayr, S. (2013) Theta oscillations at encoding mediate the context-dependent
893 nature of human episodic memory. *Curr Biol* 23:1101-6
- 894 Szczepanski, S. M., Konen, C. S. and Kastner, S. (2010) Mechanisms of spatial attention control in frontal
895 and parietal cortex. *J Neurosci* 30:148-60
- 896 Tamura, H., Kaneko, H., Kawasaki, K. and Fujita, I. (2004) Presumed inhibitory neurons in the macaque
897 inferior temporal cortex: Visual response properties and functional interactions with adjacent
898 neurons. *Journal of Neurophysiology* 91:2782-2796
- 899 Thut, G., Nietzel, A., Brandt, S. A. and Pascual-Leone, A. (2006) Alpha-band electroencephalographic
900 activity over occipital cortex indexes visuospatial attention bias and predicts visual target
901 detection. *J Neurosci* 26:9494-502
- 902 van Diepen, R. M., Cohen, M. X., Denys, D. and Mazaheri, A. (2015) Attention and temporal expectations
903 modulate power, not phase, of ongoing alpha oscillations. *J Cogn Neurosci* 27:1573-86
- 904 van Kerkoerle, T., Self, M. W., Dagnino, B., Gariel-Mathis, M. A., Poort, J., van der Togt, C. and
905 Roelfsema, P. R. (2014) Alpha and gamma oscillations characterize feedback and feedforward
906 processing in monkey visual cortex. *Proc Natl Acad Sci U S A*
- 907 van Wijk, B. C., Beudel, M., Jha, A., Oswal, A., Foltynie, T., Hariz, M. I., Limousin, P., Zrinzo, L., Aziz, T. Z.,
908 Green, A. L., Brown, P. and Litvak, V. (2016) Subthalamic nucleus phase-amplitude coupling
909 correlates with motor impairment in Parkinson's disease. *Clin Neurophysiol* 127:2010-9
- 910 VanRullen, R. (2016) Perceptual Cycles. *Trends Cogn Sci* 20:723-35
- 911 Varela, F., Lachaux, J. P., Rodriguez, E. and Martinerie, J. (2001) The brainweb: phase synchronization
912 and large-scale integration. *Nat Rev Neurosci* 2:229-39
- 913 Vijayan, S. and Kopell, N. J. (2012) Thalamic model of awake alpha oscillations and implications for
914 stimulus processing. *Proc Natl Acad Sci U S A* 109:18553-8

- 915 von Stein, A., Chiang, C. and Konig, P. (2000) Top-down processing mediated by interareal
916 synchronization. *Proc Natl Acad Sci U S A* 97:14748-53
- 917 Voytek, B., Canolty, R. T., Shestyuk, A., Crone, N. E., Parvizi, J. and Knight, R. T. (2010) Shifts in gamma
918 phase-amplitude coupling frequency from theta to alpha over posterior cortex during visual
919 tasks. *Front Hum Neurosci* 4:191
- 920 Voytek, B., Kayser, A. S., Badre, D., Fegen, D., Chang, E. F., Crone, N. E., Parvizi, J., Knight, R. T. and
921 D'Esposito, M. (2015) Oscillatory dynamics coordinating human frontal networks in support of
922 goal maintenance. *Nat Neurosci* 18:1318-24
- 923 Wang, L., Jensen, O., van den Brink, D., Weder, N., Schoffelen, J. M., Magyar, L., Hagoort, P. and
924 Bastiaansen, M. (2012) Beta oscillations relate to the N400m during language comprehension.
925 *Hum Brain Mapp* 33:2898-912
- 926 Wang, Y., Fujita, I. and Murayama, Y. (2000) Neuronal mechanisms of selectivity for object features
927 revealed by blocking inhibition in inferotemporal cortex. *Nature Neuroscience* 3:807-813
- 928 Watrous, A. J., Lee, D. J., Izadi, A., Gurkoff, G. G., Shahlaie, K. and Ekstrom, A. D. (2013) A comparative
929 study of human and rat hippocampal low frequency oscillations during spatial navigation.
930 *Hippocampus* 23:656-661
- 931 Watrous, A. J., Deuker, L., Fell, J. and Axmacher, N. (2015) Phase-amplitude coupling supports phase
932 coding in human ECoG. *Elife* 4:
- 933 Welberg, L. (2013) Cognitive neuroscience: Rules of neural engagement. *Nature reviews. Neuroscience*
934 14:1
- 935 Wimmer, R. D., Schmitt, L. I., Davidson, T. J., Nakajima, M., Deisseroth, K. and Halassa, M. M. (2015)
936 Thalamic control of sensory selection in divided attention. *Nature* 526:705-9
- 937 Womelsdorf, T., Fries, P., Mitra, P. P. and Desimone, R. (2006) Gamma-band synchronization in visual
938 cortex predicts speed of change detection. *Nature* 439:733-6
- 939 Womelsdorf, T., Schoffelen, J. M., Oostenveld, R., Singer, W., Desimone, R., Engel, A. K. and Fries, P.
940 (2007) Modulation of neuronal interactions through neuronal synchronization. *Science*
941 316:1609-12
- 942 Worden, M. S., Foxe, J. J., Wang, N. and Simpson, G. V. (2000) Anticipatory biasing of visuospatial
943 attention indexed by retinotopically specific alpha-band electroencephalography increases over
944 occipital cortex. *J Neurosci* 20:RC63
- 945 Zhang, S., Xu, M., Kamigaki, T., Hoang Do, J. P., Chang, W. C., Jenvay, S., Miyamichi, K., Luo, L. and Dan, Y.
946 (2014) Selective attention. Long-range and local circuits for top-down modulation of visual
947 cortex processing. *Science* 345:660-5
- 948
- 949

950 Figure Legends

951 **Figure 1:** The communication-through coherence (CTC) and gating through inhibition (GTI) hypotheses. a. Two
 952 pools of neurons (A and B; e.g. in V1) are connected to a pool of neurons (C; e.g. V4). In this example, pool A
 953 communicates with C (solid line) while functional connectivity between B and C is suppressed (dashed line). b.
 954 Communication through coherence (CTC). The waveforms represent oscillatory population activity (as measured in
 955 the LFP) in the three regions whereas the small vertical lines represent spiking activity. The phase of the oscillatory
 956 activity modulates the excitability and thus spike timing, i.e. it is the phase relationship between the regions
 957 determining the routing. The neurons in A and C oscillate in phase, whereas the neurons in B do not oscillate in
 958 phase with C. It has been proposed that this mechanism is implemented by gamma band oscillations (>30Hz) (Fries
 959 2005) c. Gating by inhibition (GBI): The flow of information is controlled by an increase of alpha-band oscillations
 960 (~10Hz) which inhibits firing in pool B, and a decrease in alpha oscillations of neurons in A and C allowing
 961 communication by release from inhibition (Jensen and Mazaheri 2010). It is the magnitude of the pulses of inhibition
 962 and thus the alpha power that controls the routing.

963 **Figure 2:** The new framework. The synchronization in the alpha-band establishes the functional connection between
 964 A and C. This allows for representational specific neuronal firing reflected by the gamma band activity to flow to
 965 region C. The blocking of communication between B and C is achieved by high alpha power in B and an
 966 asynchrony between B and C. Therefore both modulations in alpha-band power, as in gating by inhibition, and
 967 phase-synchronization between the regions, as in CTC, are determining the routing of information between regions.
 968 Note that phase-synchronization is assumed in the alpha band and the information transfer is reflected by gamma band
 969 activity.

970 **Figure 3:** Exchange of phase coded information. **a.** Two stimuli processed by two pools of neurons A and B, e.g. in
 971 V1. The pools both project to a pool of neurons C downstream in the hierarchy, e.g. in V4. Because of this
 972 bottleneck in the visual system, it is important that neurons coding for A and B in V1 are not activated
 973 simultaneously. For the information related to the two stimuli to be transferred from V1 to V4, we propose two
 974 mechanisms **b.** A single alpha generator in V1 controls for the timing of activation of neurons in pool A and B as
 975 reflected in the gamma band. The activation of the most excitable neurons, i.e. cells in pool A, overcomes the pulse
 976 of inhibition early in the alpha cycle followed by neurons in pool B (see Jensen et al. 2014 for details). The temporal
 977 organisation is then transmitted to the pool of neurons in C. **c.** Another possibility is that the magnitude of the alpha
 978 oscillations is modulated locally and is lower for one of the representations compared to the other. Since the alpha
 979 inhibition is lower for A, the respective neurons fire earlier than B. This temporal organization is then transmitted to
 980 C.

981 **Figure 4:** Converging feed-forward and diverging feedback pathways. **a.** Pools of neurons A and B converge on a
 982 pool of neurons in C. Black arrows represent the converging feedforward pathway while the grey arrows represent
 983 the diverging feedback pathway **b.** Example in which two cortical columns in V1 (A,B) are connected to a column
 984 in V4 (C). Three layers are represented, the supragranular, the granular and the infragranular layers. In dark and
 985 light grays are represented in the layers involved in the feedforward and feedback pathways respectively. The layers
 986 associated with each pathway are inspired by Markov et al. (2014). The feedforward connections from the pulvinar
 987 are also indicated (purple arrows) **c.** Gamma and alpha oscillations have been shown to be prominent in the
 988 granular/supragranular and infragranular/supragranular layers respectively.

989

a

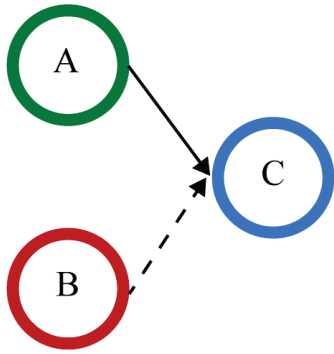

b

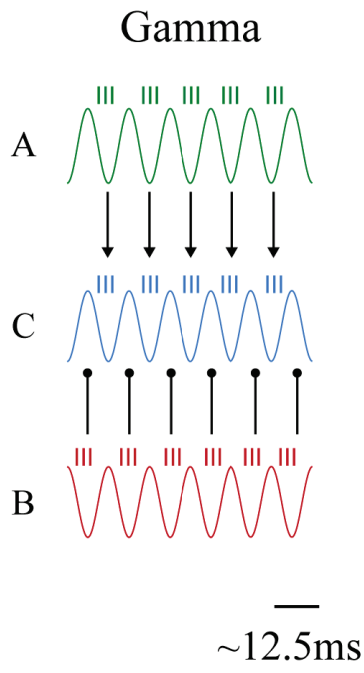

c

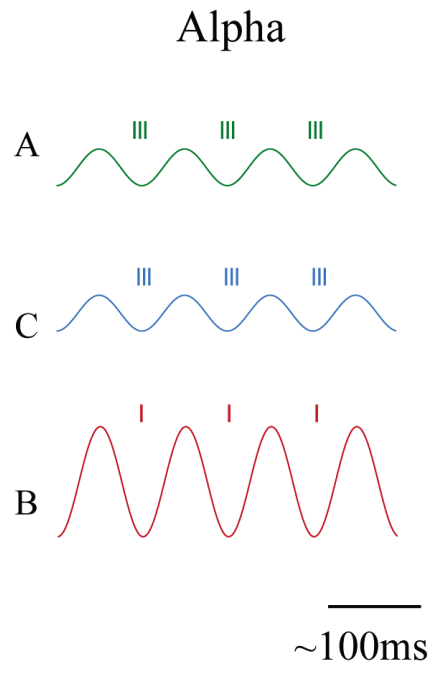

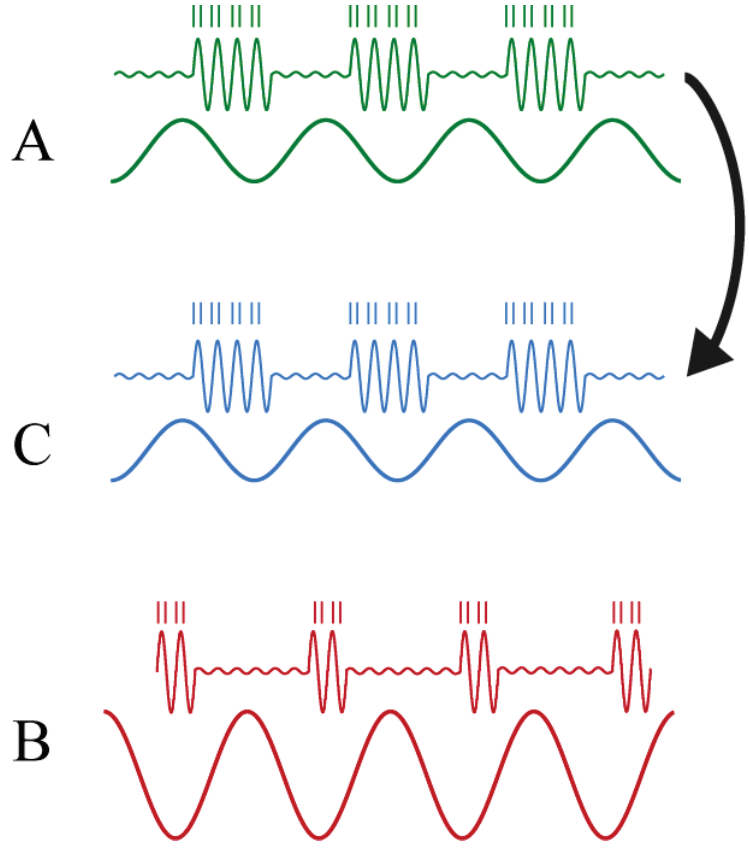
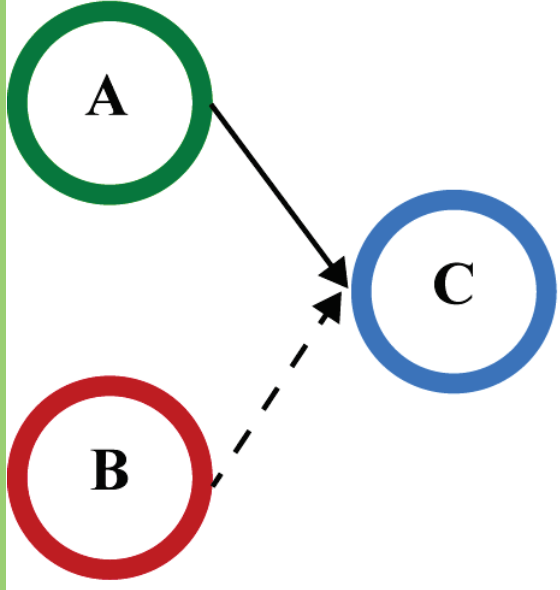

a

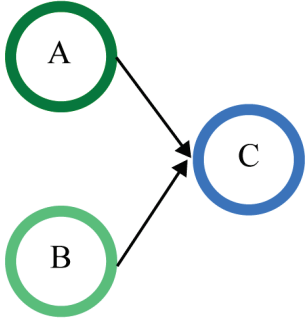

b

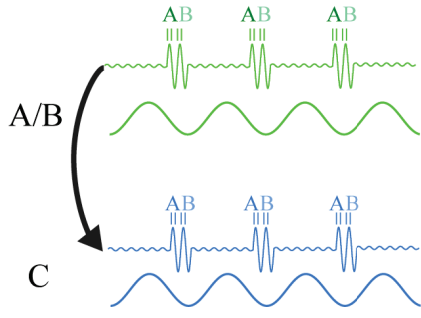

c

